

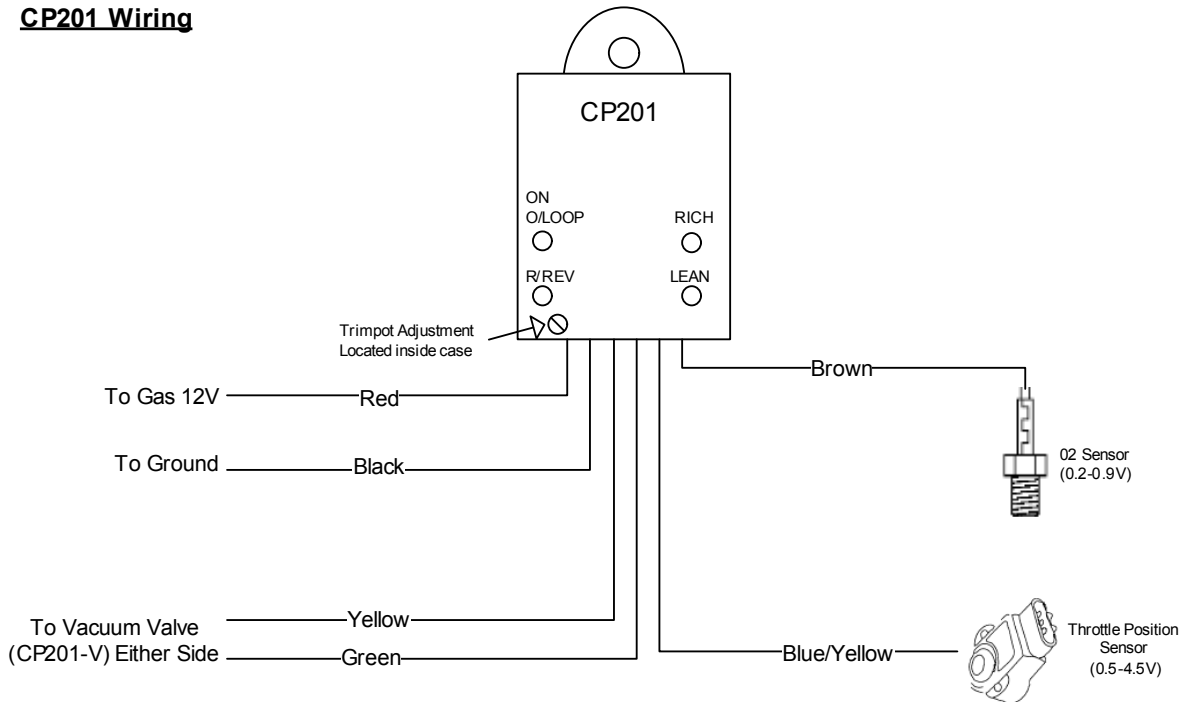

CP201 - Air/Fuel Ratio Controller for American Systems (To suit Air Valve type systems)

- The CP201 Fuel Processor offers accurate mixture control under all engine load conditions; this is done via the CP201-V Vacuum Valve which controls the operating pressure of the Converter in turn controlling fuel mixtures.
- The processor requires the connection of both the O2(Oxygen Sensor) and TPS(Throttle Position Sensor).
- The unit has an Open Loop at idle function (enriches mixtures at idle). This is adjustable via the trimpot located inside the case and indicated by the Green Led ('ON O/Loop'), when on Open Loop mode is activated. Adjust trimpot so as the green led turns off when accelerator is slightly de-pressed.
- The engines air/fuel mixture is indicated with the Red and Blue Leds, the Red indicates a Rich mixture and Blue indicates a Lean mixture.
- The unit recognizes rapid acceleration/high load conditions via the TPS and instantly enriches the engine mixtures eliminating any 'Lean' running condition. This is indicated via the Yellow Led ('R/Rev').
- The unit is water resistant, however it is recommended to mount the case inside the vehicle cabin.

CP201 Wiring



Plumbing

